

Baoli

EP 15-03

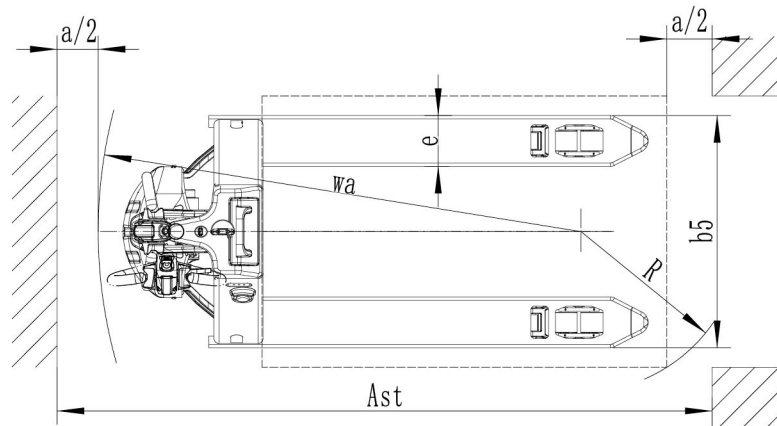

1.1	Manufacturer		KION BAOLI
1.2	Manufacturer's type designation		EP 15-03
1.3	Drive: electric, diesel, petrol, fuel gas		Electric
1.4	Operator type: hand, pedestrian, standing, seated, order-picker		Pedestrian
1.5	Rated capacity / Rated load	Q (t)	1.5
1.6	Load centre distance	c (mm)	600
1.8	Load distance, centre of drive axle to fork	x (mm)	880/950
1.9	Wheelbase	y (mm)	1120/1190
2.1	Service weight	Kg	120
2.2	Axle loading, laden front/rear	Kg	480/1140
2.3	Axle loading, unladen front/rear	Kg	90/30
3.1	Tyres: solid rubber, superelastic, pneumatic, polyurethane		PU
3.2	Tyre size, front		Ø 210x70
3.3	Tyre size, rear		2x Ø 80x60 (Ø 74x88)
3.4	Additional wheels (dimensions)		-
3.5	Wheels, number front/rear (x = driven wheels)		1x/4 (1x/2)
3.6	Tread, front	b10 (mm)	-
3.7	Tread, rear	b11 (mm)	410 / 535
4.4	Lift	h3 (mm)	115
4.9	Height drawbar in driving position min/max	h14 (mm)	750/1190
4.15	Height, lowered	h13 (mm)	80
4.19	Overall length	l1 (mm)	1550
4.20	Length to face of forks	l2 (mm)	400
4.21	Overall width	b1/b2 (mm)	685
4.22	Fork dimensions ISO 2331	s/e/l (mm)	50x150x1150
4.25	Distance between fork-arms	b5 (mm)	560 (685)
4.32	Ground clearance, centre of wheelbase	m2 (mm)	30
4.34.1	Aisle width for pallets 1000 x 1200 crossways	Ast (mm)	2145
4.34.2	Aisle width for pallets 800 x 1200 lengthways	Ast (mm)	2050
4.35	Turning radius	Wa (mm)	1330
5.1	Travel speed, laden/unladen	km/h	4,5/5
5.2	Lift speed, laden/unladen	m/s	0,017/0,020
5.3	Lowering speed, laden/unladen	m/s	0,09/0,06
5.8	Max gradeability, laden/unladen	%	6/16
5.10	Service brake		Electromagnetic
6.1	Drive motor rating S2 60 min	kW	0.75
6.2	Lift motor rating at S3 15%	kW	0.7
6.3	Battery according to DIN 43531/35/36 A, B, C, no		-
6.4	Battery voltage/nominal capacity K5	V/Ah	24 V / 20 Ah
6.5	Battery weight	kg	7
6.6	Energy consumption according to VDI cycle	kWh/h	0.2
8.1	Type of drive unit		DC
10.7	Sound pressure level at driver's seat	dB (A)	<74

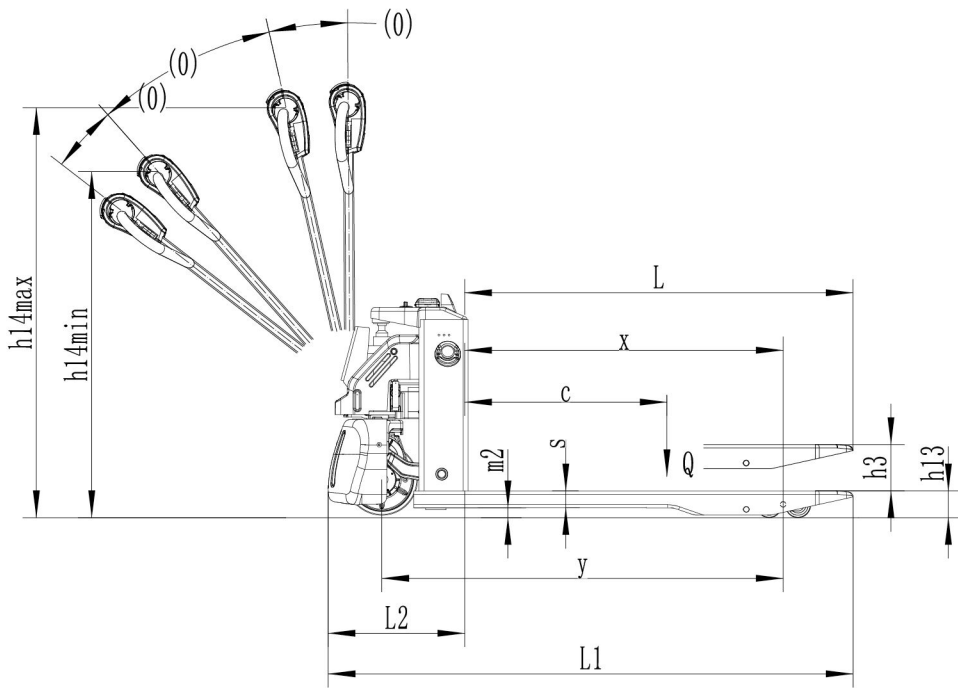

EP 15-03



The Baoli EP 15-03 is an efficient and versatile pallet truck suitable for transporting goods economically and without fatigue. It is a good choice for storing and retrieving goods. The 24 V / 20 Ah maintenance-free Lithium-ion batteries ensure easy handling. They can be recharged any time at a standard 220 Volt socket. The EP 15-03 is perfect for almost any internal goods transportation in small and medium-sized warehouses, especially for wholesale and retail. This pallet truck is particularly robust and ideal for long-term use.

With a load capacity of 1500 kg and tare weight of just 120 kg, the EP 15-03 efficiently operates even on tail lifts or freight elevators. The EP 15-03 impresses with its intuitive operation. All driving and lifting functions are electrically controlled. The manually operated lowering handle ensures a smooth lowering process. The extra low-mounted tiller reduces the effort required for steering. The compact dimensions, small turning radius and the possibility to operate with the tiller in vertical position make the EP 15-03 an ideal solution even for tight areas.

Technology and features

- ✓ Li-ion technology
- ✓ Maintenance-free battery
- ✓ Easy Plug & Play battery change system
- ✓ External battery charger
- ✓ Forks with an overall width of 560 or 685 mm available
- ✓ Electromagnetic parking brake
- ✓ Creep speed switch to activate the tiller in vertical position
- ✓ Service weight only 120 kg
- ✓ Metal drive wheel cover to protect operator's feet
- ✓ No gas emissions.

